

# ORIGINAL OPERATION, PARTS & **SAFETY** MANUAL



# **SIGNODE**<sup>®</sup>

## GRIPPACK 114

### BATTERY POWERED SEALER

**NOTE: Fully charge battery before first use of tool.**



**IMPORTANT!**  
**DO NOT DESTROY**

It is the customer's responsibility to  
have all operators and servicemen  
read and understand this manual.

Contact your local Signode representative  
for additional copies of this manual.

***READ ALL INSTRUCTIONS BEFORE OPERATING THIS SIGNODE PRODUCT***

# **WARNING**

**READ THESE INSTRUCTIONS CAREFULLY.  
FAILURE TO FOLLOW THESE INSTRUCTIONS CAN RESULT IN SEVERE PERSONAL INJURY.**

## **1. STRAP BREAKAGE HAZARD**

Improper operation of the tool or sharp corners on the load can result in strap breakage during tensioning, which could result in the following:

- A sudden loss of balance causing you to fall.
- Both tool and strap flying violently towards your face.

Failure to place the strap properly around the load or an unstable or shifted load could result in a sudden loss of strap tension during tensioning. This could result in a sudden loss of balance causing you to fall.

Read the tool's operating instructions. If the load corners are sharp use edge protectors. Place the strap correctly around a properly positioned load.

- Positioning yourself in-line with the strap, during tensioning and sealing, can result in severe personal injury from flying strap or tool. When tensioning or sealing, position yourself to one side of the strap and keep all bystanders away.
- Using strap not recommended for this sealer can result in strap breakage during sealing. Use the correct Signode products for your application.

## **2. TOOL CARE**

Take good care of the tool. Inspect and clean it daily, lubricate it weekly and adjust when necessary. Replace any worn or broken parts.

## **3. WORK AREA**

Keep work areas uncluttered and well lighted.

## **4. FALL HAZARD**

Maintaining improper footing and/or balance when operating the tool can cause you to fall. Do not use the tool when you are in an awkward position.

## **5. STRAPPING**

Several types of strap can be used with this tool. Use the correct Signode products for your application. If you need help contact your Signode Representative.

## **6. CUTTING TENSIONED STRAP**

Use only cutters designed for cutting strap; never use claw hammers, crowbars, chisels, axes or similar tools. Such tools will cause the strap to fly apart with hazardous force. Before using any Signode product, read its Operation and Safety Manual.

# **WARNING**

**READ THESE INSTRUCTIONS CAREFULLY.  
FAILURE TO FOLLOW THESE INSTRUCTIONS CAN RESULT IN SEVERE PERSONAL INJURY.**

## **7. GUARD AGAINST ELECTRIC SHOCK**

## **8. CONSIDER WORK AREA ENVIRONMENT**

- Prevent body contact with grounded surfaces, such as pipes, radiators, ranges, refrigerator enclosures.
- When tool and charger are used outdoors, use only extension cords intended for outdoors and so marked.
- Wear protective gloves and non-skid footwear when working outdoors.
- Do not expose power tools directly to rain.
- Never operate tool in presence of gases or flammable liquids.

## **9. Never allow visitors to contact tool or extension cords. All visitors should be kept away from work area.**

## **10. DO NOT ABUSE TOOL**

- Keep handle dry, clean and free from oil and grease.
- Always keep cord from heat, oil and sharp edges.
- Always store idle tool in dry, high or locked-up place.
- Always remove battery from tool when not in use or before servicing.
- To avoid unintentional starting, never carry plugged-in tool with finger on switch.

## **11. MAINTAIN TOOL WITH CARE**

**Check Damaged Parts.** Check for alignment of moving parts, binding of moving parts, breakage of parts, mounting, and any other condition that may affect its operation. A guard or other part that is damaged should be properly repaired or replaced by an authorized service center unless otherwise indicated elsewhere in this instruction manual. Have damaged switches replaced by authorized service center. Do not use tool if switch does not turn it on and off.

- When servicing double insulated tool, use identical replacement parts.
- Keep tool clean for better and safer performance.
- Inspect tool, battery and charger periodically and, if damaged, have repaired by authorized service facility.

## **12. USE FOR THE INTENDED PURPOSE**

This tool is designed for bundling round packages with Signode brand steel strapping.

### **POSSIBLE MISUSES**

The use of any other strapping material may void this tool's warranty.

# **WARNING**



## **TRAINING**

Read the operating instructions carefully. This tool must not be used by persons not properly trained in its use. Be certain that you receive proper training from your employer. If you have any questions contact your Signode Representative.



## **EYE INJURY HAZARD**

Failure to wear safety glasses with side shields can result in severe eye injury or blindness. Always wear safety glasses with side shields which conform to ANSI Standard Z87.1 or EN 166.



## **CUT HAZARD**

Handling strap or sharp parts could result in cut hands or fingers. Wear protective gloves.



## **SOUND PROTECTION**

When operating the tool, wear ear protection.



## **ENVIRONMENTAL PROTECTION**

Charger and batteries should be sorted for environmental-friendly recycling. Do not open the battery. Do not throw the used battery into household waste, fire or water.



## **DISPOSAL**

This tool is manufactured without any physical or chemical substances which could be dangerous to health. The legal prescriptions for disposal of all the parts must be observed. The electrical assemblies should be dismantled so that the mechanical, electro-mechanical and electronic components can be disposed of separately.



## **DO NOT USE WATER**

Do not use water or stream to clean the tool.



## **POWER SOURCE**

Before starting preventive or corrective maintenance, remove the battery from the tool. Always inspect the electrical plug and cable on charger before use. If damaged, they must be replaced by qualified personnel.

## TABLE OF CONTENTS

	Page		Page
General Safety Instructions	2	Troubleshooting:	
Specifications	5	Guides	15
Major Components	6	Indicator Lights	19
Battery Charger	7	Tool Maintenance	20
Battery Installation	8	Maintenance Procedures	21
Operating Instructions	9	Declaration of Conformity	25
Joint Formation & Inspection	10		
Replacement Parts	11		

### Signode GRIPPACK 114

Part No. 800250



### STRAP SPECIFICATIONS

MODEL	STRAP			SEALS	RECOMMENDED TENSIONER
	TYPE	WIDTH	THICKNESS		
GRIPPACK 114	Magnus Apex Plus	1.250" (32mm)	.025" to .031" (.63-.80mm)	114P 114OF	GripPack Tensioner

### TOOL SPECIFICATIONS

MODEL	DIMENSIONS	WEIGHT (W/ BATTERY)	SOUND PRESSURE
GRIPPACK 114	14.25" X 3.25" X 7.25" (362mm X 83mm X 184mm)	7.5 LBS (3.4 kg)	38 DB

## MAJOR COMPONENTS

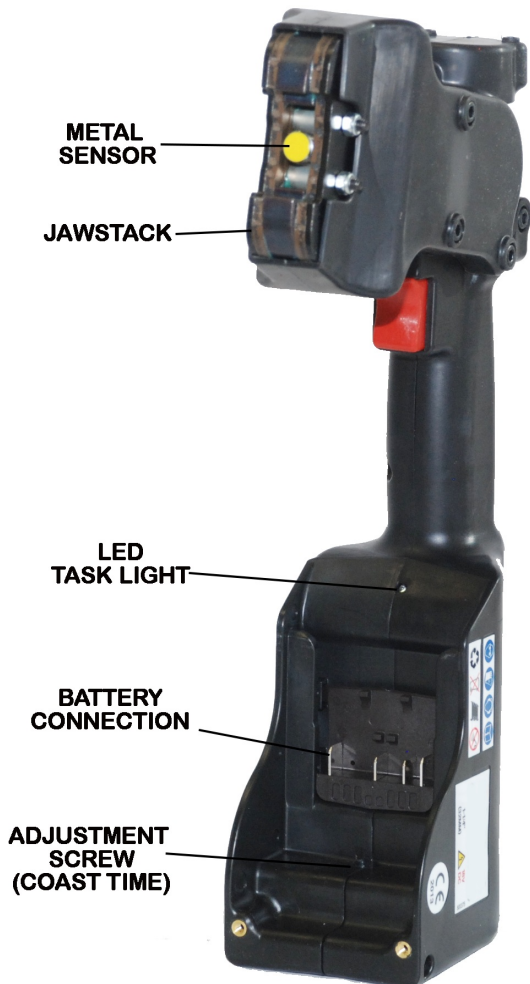

### PRODUCT IDENTIFICATION

A two letter date code can be found on every tool. Contact your local Signode representative to assist in identifying the production month and year of the tool.

Date codes can also be used to properly identify service parts for this tool.

## BATTERY INFORMATION & CHARGING

Plug charger into your standard power outlet.

With no battery pack inserted, the charger's green indicator light will go ON. This indicates the charger is receiving power and the charger is ready for operation.

When you insert the battery pack into the charger. The charger's green indicator light will begin to "BLINK". This indicates that the battery is receiving a fast charge.

When the indicator light stops "BLINKING" (and becomes a steady green light) fast charging is complete. The battery pack is fully charged and can be removed from the charger.

The battery pack may be used even though the light may still be blinking. The light may require more time to stop blinking depending on temperature.

The purpose of the green light is to indicate that the battery pack is fast-charging. It does not indicate the exact point of charge. The light will stop blinking in less time if the battery pack was not completely charged.

When you begin the charging process of the battery pack, a steady red light could also mean the battery pack is too hot or too cold.

Fast charging is only possible when the temperature range of the battery pack is between 32F (0C) and 113F (45C). When needed, the internal fan of the charger will turn on to aid the charging process and speed.

As soon as the battery pack reaches the correct temperature range, the battery charger will automatically switch to fast charging.

If the red indicator light is "BLINKING", the battery pack cannot accept a charge.

- Check to make sure the battery pack is inserted to the charger properly.
- Clean the contacts of the charger or battery pack (e. g. by inserting and removing the battery several times) or replace the battery pack as required.

When the battery pack is fully charged, unplug the charger (unless you're charging another battery pack) and install the battery pack back into the tool.



## INSTALLING A BATTERY

1. Hold the tool firmly with one hand.
2. Using your other hand, insert the battery into the tool with a sliding motion.
3. Firmly push the battery until fully seated. When fully seated the battery locks in place.

The Green indicator light will flash for approximately 5 seconds while the tool energizes. Once the light stops flashing the tool is ready for use.

4. To remove the battery press the Red release button on the battery and slide out.



**NOTE:** The power indicator light on the top of the tool will flash Green indicating the battery has enough charge. If the indicator light flashes Red, charge the battery accordingly.

## REPLACEMENT BATTERIES & CHARGERS

110 VOLT	BATTERY	CHARGER
	P/N 800294	P/N 800293

220 VOLT	BATTERY	CHARGER
	P/N 800386	P/N 800385

## JOINT FORMATION & INSPECTION

An improperly formed joint, or a joint with an incorrect number of notches, could result in strap separation. Before moving any package, be certain that the joint is formed as shown in the illustration. If not, remove the strap and check the tool for worn or broken parts. Repair the tool before applying another strap. Failure to follow this procedure could result in serious injury or death. If you have questions regarding proper joint formation, contact your Signode Sales Representative.

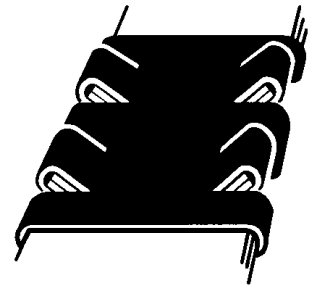

Before making a double reverse notch seal joint, read this tool's Operation, Parts and Safety Manual. A properly formed double reverse notch joint will appear as shown in the illustration. Always use the correct number of seals recommended by your Signode Sales Representative.

If the double reverse notch joint does not appear as shown in the illustration, proceed as follows:

- A. Review the tool's operating instructions to be certain that the tool is being operated properly before applying another strap.
- B. Cut the strap off and apply a new strap and seal.

Tuck strap end back into the dispenser when not in use.



## OPERATING INSTRUCTIONS

# **WARNING**

**Wear safety glasses and gloves. Stand to one side of the strap when sealing.  
Make sure all bystanders are clear before proceeding.**

**PLEASE NOTE:** Do not operate tool without strap, as damage to the tool may occur.

1. Thread the strap from the dispenser through a Signode 114P or 114OF seal.



Encircle the bundle and rethread the strap end through the seal.

2. Bend the strap end backwards as shown.

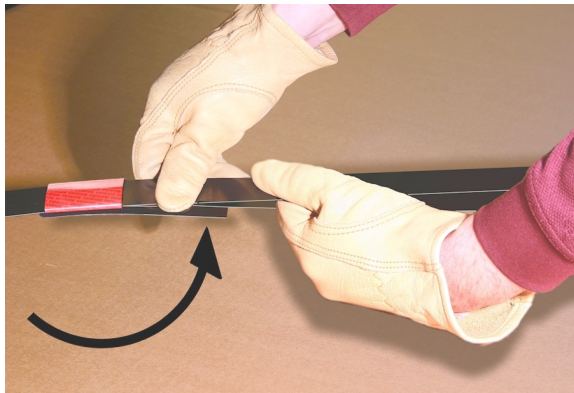

3. Tension the strap as required. Refer to the strap tensioner manual for the proper use of the tool.



4. Position the sealer jaws over one end of the seal. Press the switch located on the handle grip. Once completed, move the sealer jaws to the other end of the seal and notch the seal a second time.



5. Once the second notch has been made the seal joint can be inspected and the strap tensioner can be removed.

## REPLACEMENT PARTS

<u>KEY</u>	<u>QTY</u>	<u>PART NO.</u>	<u>DESCRIPTION</u>
1	1	800234	GEAR HOUSING
2	1	800332	RIGHT HANDLE ASSEMBLY
3	1	800333	LEFT HANDLE ASSEMBLY
4	1	800238	LEFT SIDE PLATE
5	1	800239	RIGHT SIDE PLATE
6	2	800266	NOTCHER
7	1	800526	WORM GEAR
8	1	800241	ECCENTRIC PIN
9	2	800240	LINKAGE
10	1	800242	LINK PIN
11	4	800243	SEALER LINK
12	2	800245	JAW
13	2	800267	LOWER JAW PIN
14	1	800244	UPPER JAW PIN
15	1	800285	UPPER JAW PIN
16	2	800246	SPACER
17	1	800063	BEARING CAP
18	1	800236	GEAR HOUSING COVER
20	1	800527	WORM
21	1	800263	MOTOR MOUNT
24	1	800265	RUBBER BOOT
25	1	800060	TRIGGER SPRING
26	1	800268	JAW SPACER
27	1	800018	TRIGGER
28	1	800005	CONTACT PLATE
31	1	800100	PCB MOUNTING BRACKET
32	1	800286	SPACER
33	1	800522	CV SHAFT
34	1	425321	DRIVE CONNECTOR
38	1	426146	ROLLER BEARING
39	1	800311	O RING 12MM X 1.5
40	1	800309	NEEDLE BEARING 0810-RS
41	1	800310	BEARING 71906C
42	1	800312	BALL BEARING 6806
43	8	170304	M5 X 16 SHCS
44	14	280851	M4 X 12 SHCS
45	1	800059	O-RING SAE# 31 (50 DUROMETER)
46	1	800062	O-RING SAE# 26
47	2	800058	1.5 WIDE X Ø30.0 I.D. METRIC O-RING
48	8	800013	M3 X 5 SBHCS
49	3	M4 X 5	M4 X 5 SBHCS

<u>KEY</u>	<u>QTY</u>	<u>PART NO.</u>	<u>DESCRIPTION</u>
50	2	800102	M2 X 10 SHCS
51	2	800049	M2 HEX JAM NUT
52	4	422835	Ø5 X 12 DOWEL PIN
53	2	280809	M5 X 35 SHCS
54	2	280819	M5 HEX LOCKNUT
55	2	010031	M5 X 25 SHCS
58	4	262456	M3 X 6 SHCS
59	4	434097	8mm EXT. RET. RING (TA# 5100-31)
60	1	293902	M4 X 5 SSS CUP
63	3	800325	SBHCS M4 X 5
64**	2	299044	SHSS M3 X 5
70	1	800309	SLEEVE BEARING
71	2	800295	12MM BALL BEARING
72	1	800254	IDLER CARRIAGE ASSEMBLY
73	12	800258	IDLER GEAR
74	3	800256	RING GEAR
75	2	800255	IDLER CARRIAGE ASSEMBLY
76	1	800260	END PLATE
77	1	800323	1.5 WIDE X Ø24.0 I.D. METRIC O-RING
78	2	800324	1.5 WIDE X Ø19.0 I.D. METRIC O-RING
79	1	800296	RETAINING RING
80	1	800375	NAMEPLATE
81	1	800376	INFORMATION SIGN
82	1	800377	INFORMATION SIGN
83	1	423953	WARNING SIGN
84	1	436387	INFORMATION SIGN

- When ordering parts please indicate tool model, part number and description.
- Recommended spare parts are underlined and should be stocked.
- Common hardware parts can be obtained at any local hardware supply.

\*\* Use Loctite #222 (Purple) or equivalent.

## **⚠ WARNING**

Inspect all parts daily and replace them if they are worn or broken. Failure to do this can affect a product's operation and could result in serious personal injury.

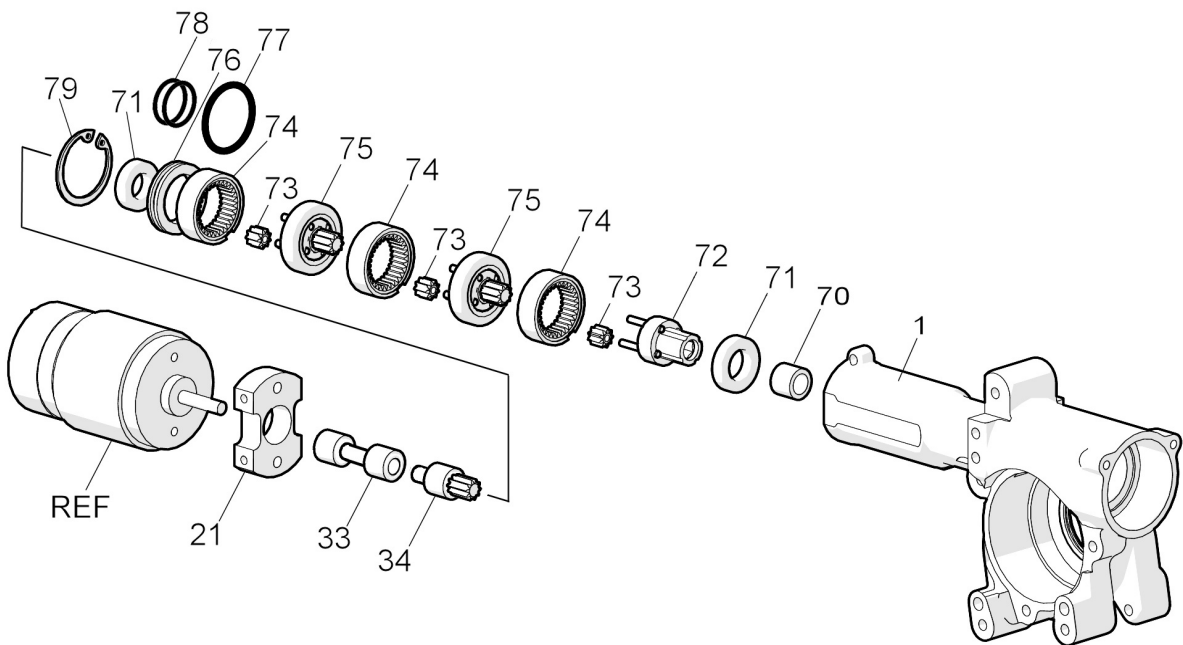
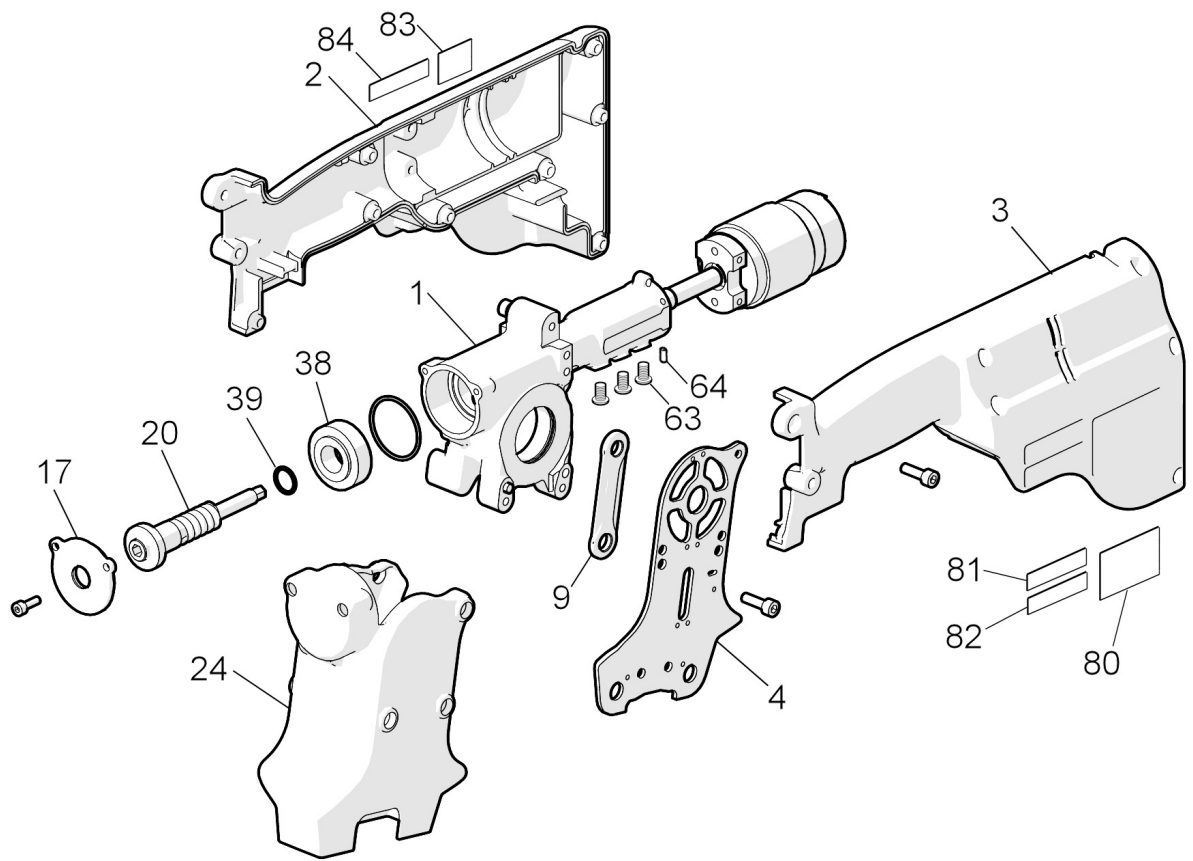

**⚠ WARNING**  
 Inspect all parts daily and replace them if they are worn or broken. Failure to do this can affect a product's operation and could result in serious personal injury.

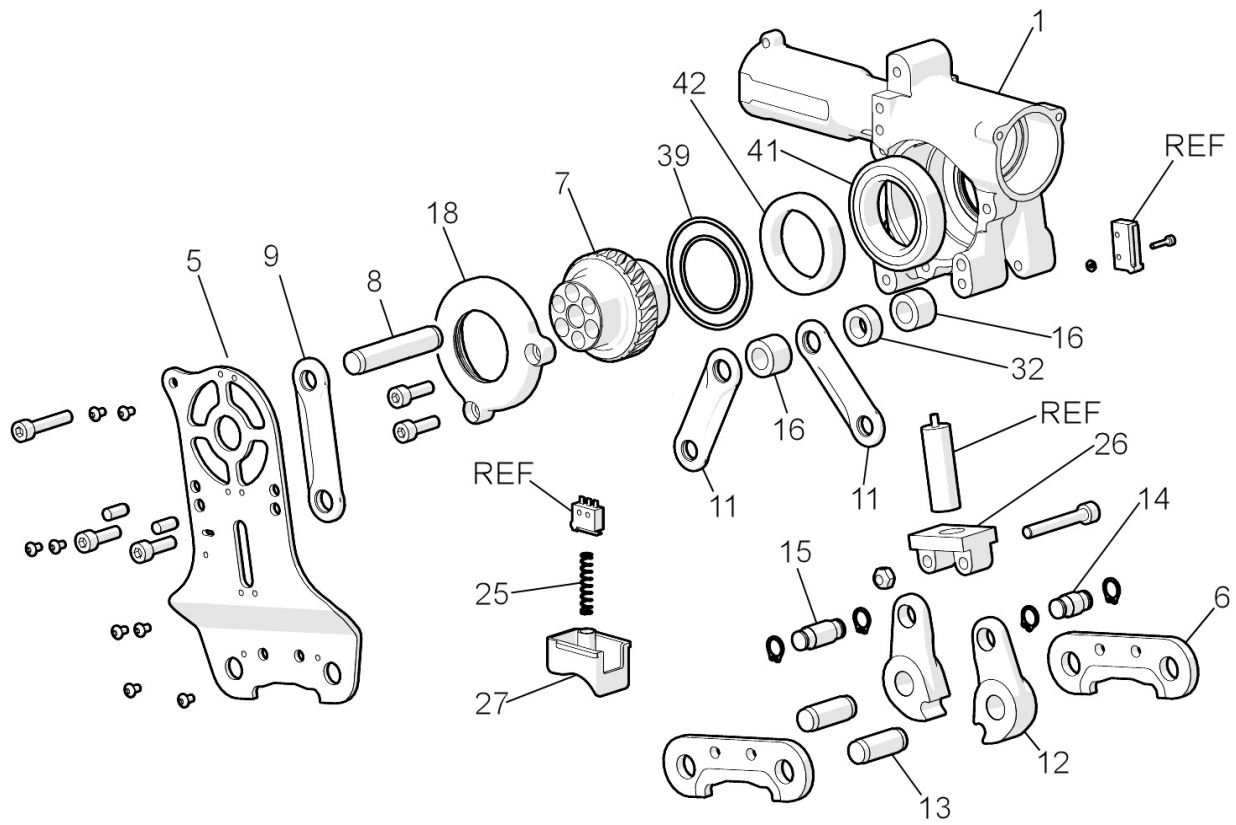

**⚠ WARNING**  
 Inspect all parts daily and replace them if they are worn or broken. Failure to do this can affect a product's operation and could result in serious personal injury.

## ELECTRICAL SERVICE SUB-ASSEMBLIES

All of the service assemblies below (Keys 1 through 8) can be order together as Signode Part No. 800532.

<u>KEY</u>	<u>QTY</u>	<u>PART NO.</u>	<u>DESCRIPTION</u>
------------	------------	-----------------	--------------------

1	1	800533	PCB
2	1	800534	Contact Plate
3	1	800535	Snap Switch
4	1	800536	Snap Switch
5	1	800537	LED
6	1	800538	LED
7	1	800539	Motor
8	1	800540	Metal Sensor

The following service items include wires and all connectors needed for replacement.

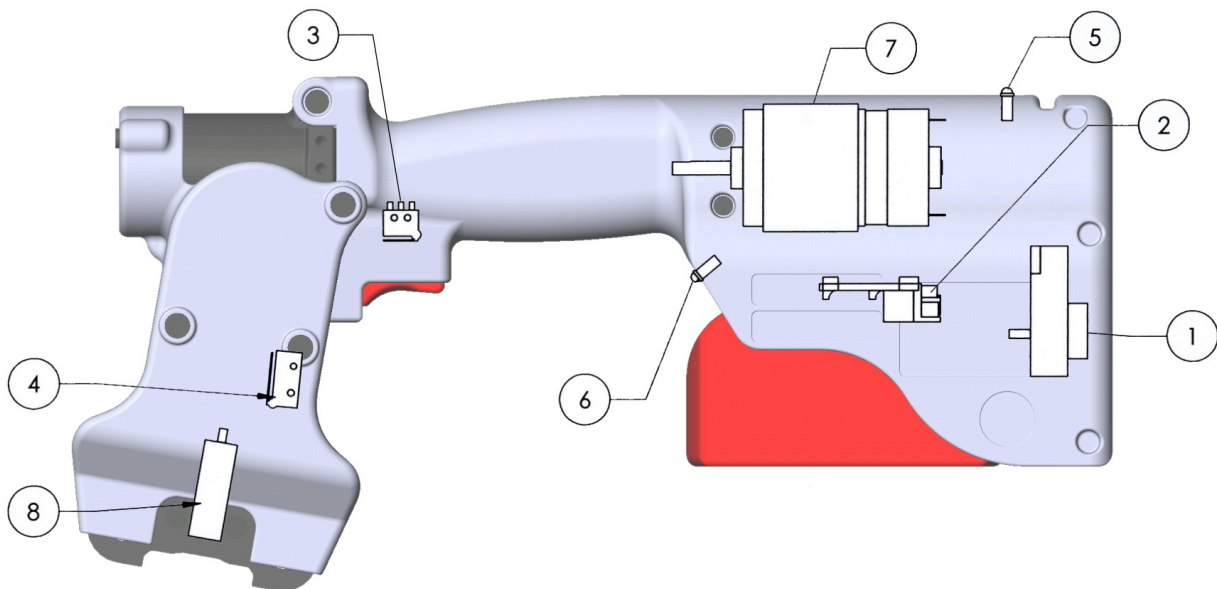

# TROUBLESHOOTING GUIDES

## 1 TOOL DOES NOT OPERATE

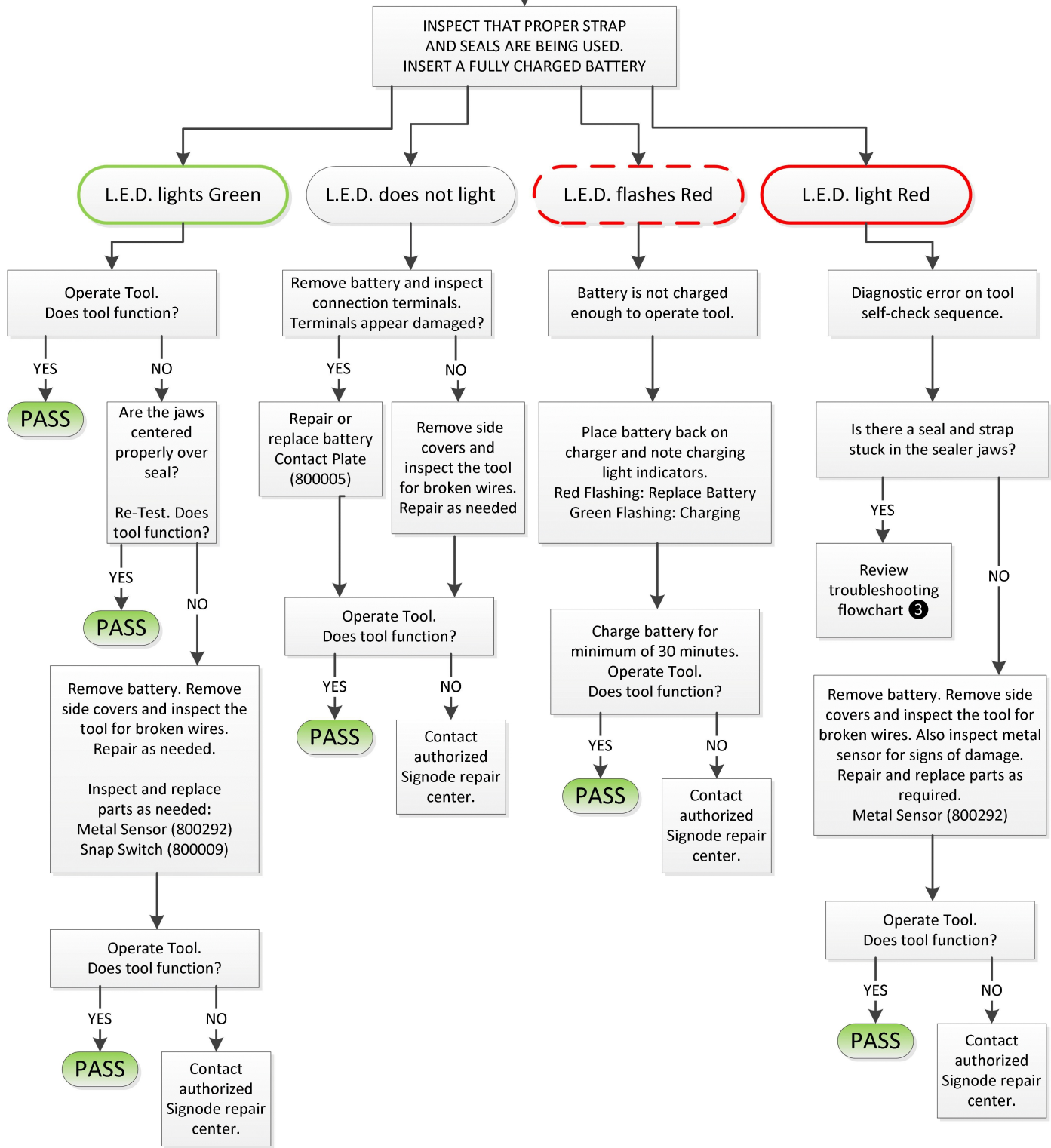

# TROUBLESHOOTING GUIDES

## 2 TOOL OPERATES SLOW AND/OR POOR STRAP JOINT FORMATION

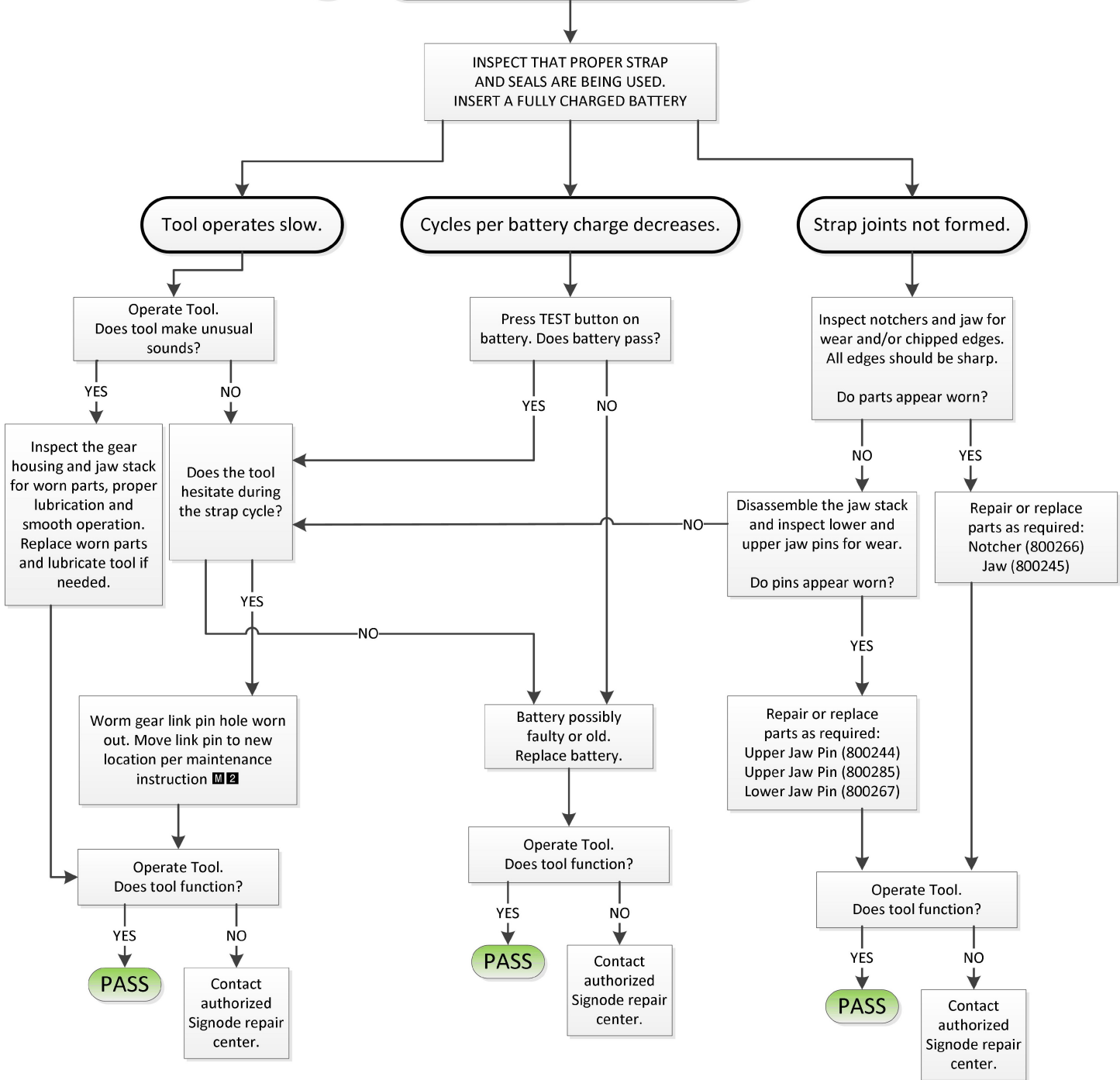



# TROUBLESHOOTING GUIDES

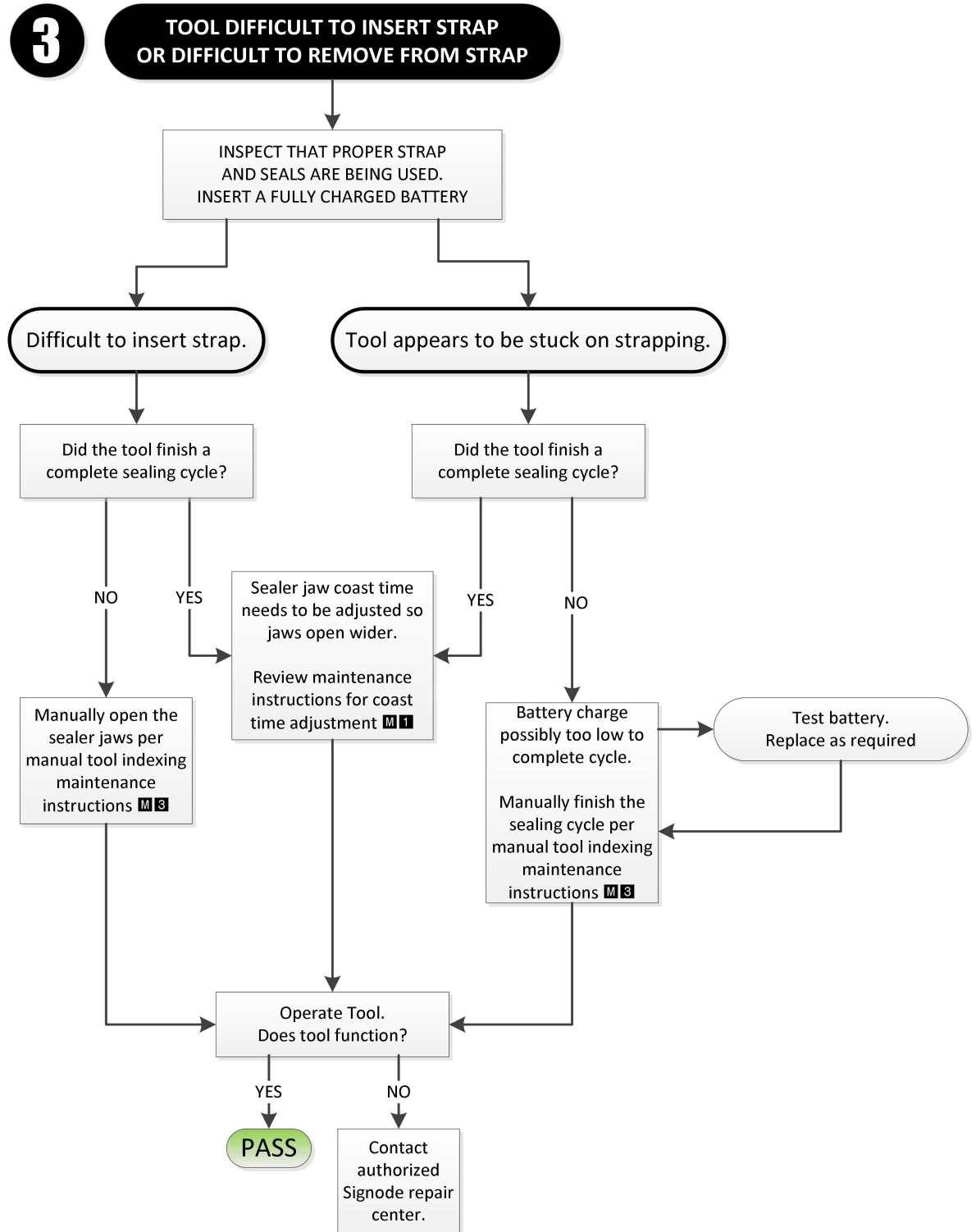

**4**

**TOOL CYCLES CONSTANTLY**

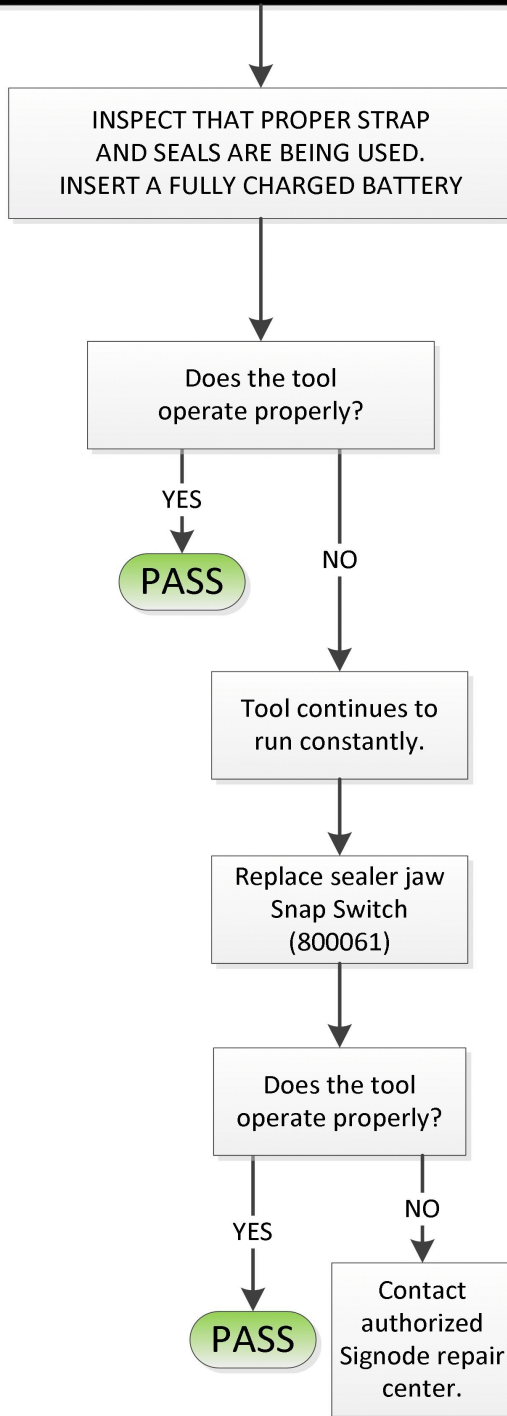

## TROUBLESHOOTING - INDICATOR LIGHTS



	Charger is plugged in and receiving power.
	Battery is receiving a Quick Charge.
	Battery is too hot or cold to receive charge. Charging starts when the battery reaches the proper temperature.
	Battery cannot accept a charge. Replace battery.

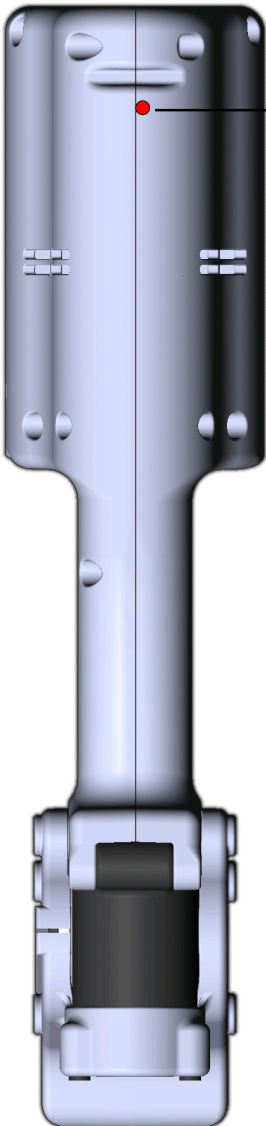

	Battery properly charged.
	Operating error. Refer to tool troubleshooting.
	Battery not properly charged to operate tool.

## TOOL MAINTENANCE

### GENERAL

The most common reason for poor tool performance and incorrectly formed straps joints is improper tool maintenance. The easiest way to determine if a tool is performing correctly is by inspecting the strap joint. Having a tool maintenance program is a simple task which consists of three parts. First, a quick daily inspection of the tool for any worn or broken parts. Secondly, keep each tool on a schedule of service intervals for cleaning and lubrication. Third, when problems do occur, use the troubleshooting guide to properly determine and fix problems before they lead to more serious tool conditions. Each of these three tasks have been outlined for this particular tool, read and understand all information for improving the life and performance of the tool.

### TOOL INSPECTION

Visually inspect the exterior of the tool on a daily basis. Decreased tool life can be prevented by early detection of broken parts. Replace all broken parts with new parts. Review any part removal, replacement & adjustment instructions found in this manual.

### SERVICE INTERVALS

Tool component wear is affected by the environment, strap/seal quantity and strap gauge which the tool is subjected to. All critical moving components of the tool should be inspected periodically. Broken parts can increase sealing effort, leading to additional component wear and produce lower joint strength.

Inspect the components of the sealing mechanism when:

- A. Joint does not appear as shown in this manual or visually it is detected that the joint is not all formed or formed improperly.
- B. Sealing effort seems sluggish or tool is difficult to remove from strap.
- C. The number of cycles from one battery charge decreases.
- D. When scheduled.

## **WARNING**

If there is any question that joint formation is not as shown or is suspect, it is important that you contact your tool representative immediately.

### TOOL LUBRICATION

Signode tools use a variety of greases and oils, all of which can be ordered through Signode. When ordering indicate tool model, part number and name.

### THREAD SEALANTS

Signode tools are assembled using a variety of thread sealants, all of which can be ordered through Signode service using the appropriate description and part number.

- Loctite #222 (Purple), Part No 422794.

## MAINTENANCE PROCEDURES - COAST TIME ADJUSTMENT **M 1**

1. Remove the battery from the tool.
2. Locate the coast-time adjustment screw located in the battery compartment.
3. Turn the adjustment screw clockwise to increase coast time (wider jaws). Turn the adjustment screw counter-clockwise to decrease coast time (narrow jaws).

Optimum jaw opening is 1.4" (36mm).

Make the coast time adjustments in small increments and test the tool in between each adjustment.

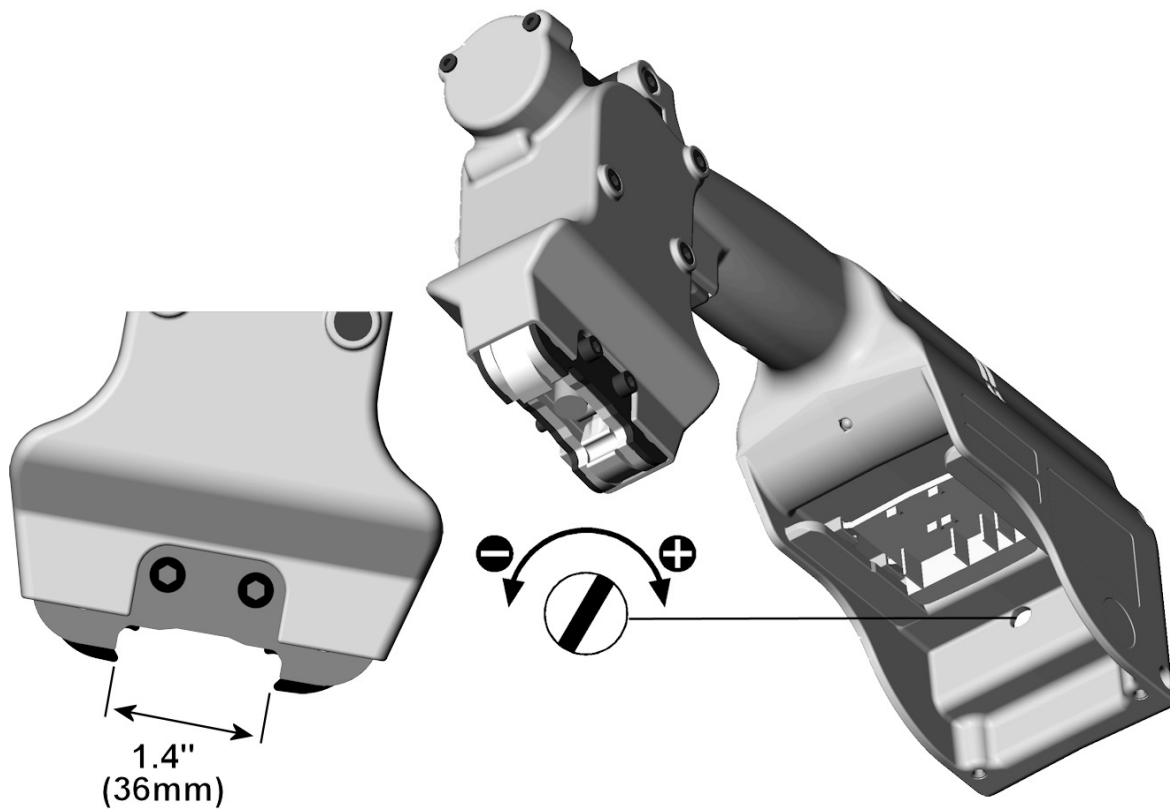

## MAINTENANCE PROCEDURES - ECCENTRIC PIN SERVICE **M 2**

1. Remove the tool battery. Remove the mounting screws which secure the rubber boot to the tool. Remove boot.

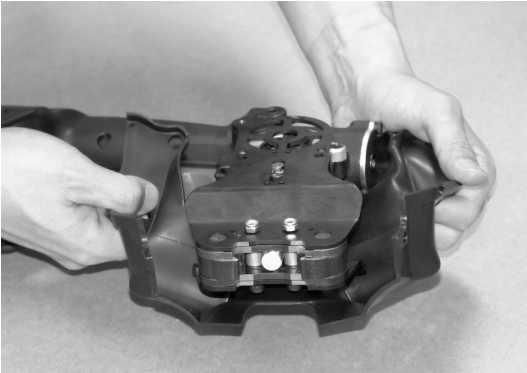

2. Continue to remove the right-hand side plate to access the eccentric pin.

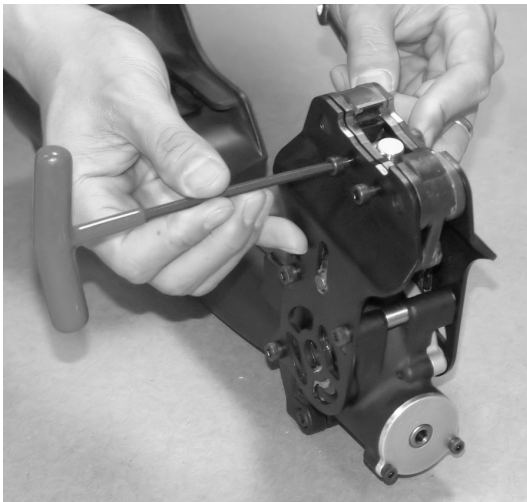

3. Lift off the link which connects the eccentric pin to the sealer jaws.

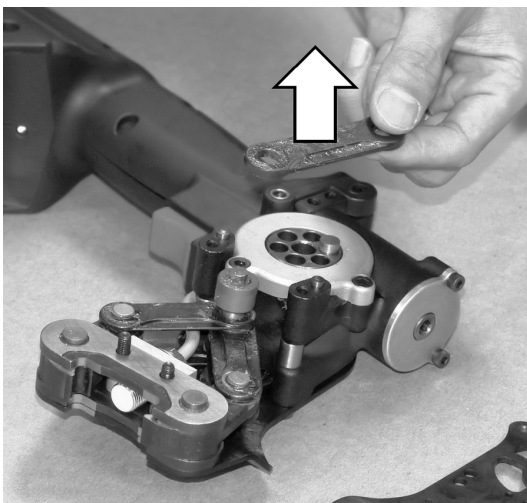

4. Mark the location of the eccentric pin on the face of the gear housing cover.

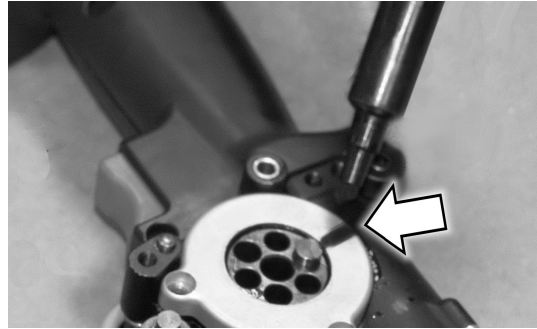

5. Lift the eccentric pin out from the tool.

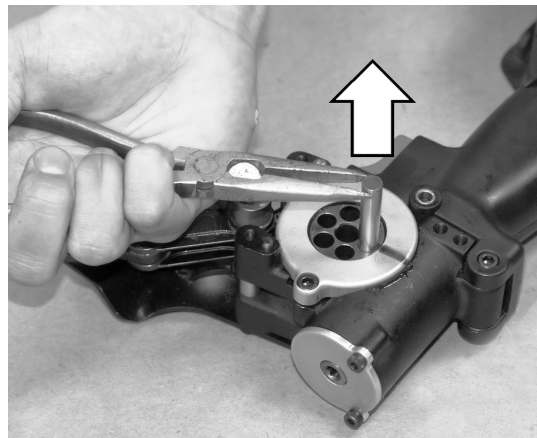

6. Manually turn the gear housing drive assembly until the next eccentric hole lines up with the mark (approximately 120 degrees).

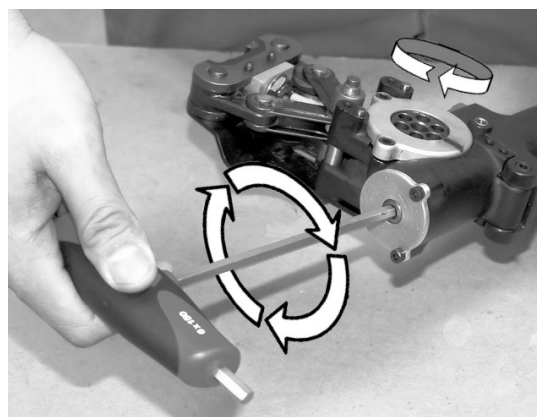

7. Lubricate and reinsert the eccentric pin into the new mounting hole (at marking). Reassemble the tool by reversing these instructions.

## MAINTENANCE PROCEDURES - MANUAL INDEXING **M 3**

Use the procedure below to manually index the tool. This is a procedure used for cycling the tool for general maintenance and/or incomplete strapping cycles.

For bench maintenance:

1. Remove the battery from the tool.
2. Pull back the rubber boot to expose the front of the gear housing.
3. Using a 6mm allen wrench, rotate the gear assembly clockwise to open and close the sealer jaws



For incomplete strap cycles:

1. Remove the battery from the tool.
2. Pull back the rubber boot to expose the front of the gear housing.
3. Using a 6mm allen wrench, rotate the gear assembly clockwise to open the sealer jaws. Continue rotating the gear housing until the tool releases from the strap.
4. Cut off and discard strap.
5. Inspect tool for problem conditions and battery for proper charge.





**EU Declaration of Conformity**  
The Supply of Machinery (Safety) Regulations  
1992 (S.I. 1992/3073)

It is hereby declared that the undermentioned machinery has been designed and constructed to comply with the health and safety requirements defined in EC Directives 2006/42/EC, 2006/95/EC and 2004/108/EC.

**Machine Supplier:** Signode  
3700 West Lake Avenue  
Glenview, IL 60026 U.S.A.

**Place of Declaration:** U.S.A.

**Declaration Date:** 1 March, 2013

**Machine Description:** Grippack

**Machine Type:** Battery Powered Hand Tool

**Provisions with which machine complies:**

2006/42/EC  
2006/95/EC  
2004/108/EC

**Harmonized EuroNorms with which machine complies:**

EN 60204-1:2006  
EN ISO 12100:2010  
EN ISO 14121-1:2007  
EN 13849-1  
EN 349  
EN 61000-6-2:2005  
EN 61000-6-4:2005

**Technical Standards with which machine complies:** NA

**EC Authorized Representatives:**

Tim Dunlavy  
Manufacturing Manager  
Signode  
3700 West Lake Avenue  
Glenview, IL 60026 U.S.A.  
Phone 800-323-2464

G. S. Leine  
Product Support Manager  
Signode Europe  
Westring 13, 40721  
Hilden Germany  
Phone 49-2103-96067-0



## SIGNODE WARRANTIES AND LIMITATIONS

Signode warrants that for a period of sixty (60) days for Signode tools from date of shipment product sold to Purchaser by Signode will be free from defects in material and workmanship under normal use. During said Warranty period, Signode agrees to replace free of charge any Signode manufactured or purchased part or component which is determined to be defective. Signode may require that the defective part or component be sent to Signode, or its designated authorized representative, freight or postage prepaid. If Purchaser requests that Signode remove and/or replace said part or component, Signode shall have the right to charge Purchaser for such work at Signode's regular service rates. Repairs to products must be made by a Signode authorized service representative; by Purchaser's employees trained by Signode who apply Signode approved repair procedures; or in accordance with repair procedures set forth in the Product Service Manual provided by Signode.

Signode warrants that for a period of thirty (30) days from the date of services provided, the products repaired will be free from defects in material and workmanship when under normal and intended use.

This Warranty extends only to the original purchase from Signode and is not transferable.

Signode warrants and represents that the products when used in accordance with instructions provided by Signode, will not infringe any patent or other proprietary right of any third party.

## DISCLAIMERS

THESE WARRANTIES ARE EXPRESSLY CONDITIONED ON:

- A. THE PROPER INSTALLATION OF EQUIPMENT AS SUPERVISED BY AN AUTHORIZED SIGNODE SERVICE REPRESENTATIVE.
- B. EQUIPMENT AND TOOLS REPAIRED BY AN AUTHORIZED SIGNODE SERVICE REPRESENTATIVE.
- C. PURCHASER FOLLOWING THE SIGNODE PRESCRIBED MAINTENANCE SCHEDULE, OPERATING AND OTHER INSTRUCTIONS.

FAILURE TO FOLLOW THE ABOVE EXPRESS CONDITIONS SHALL VOID ALL WARRANTIES OTHERWISE APPLICABLE TO THE PRODUCTS OR SERVICES.

SIGNODE EQUIPMENT AND TOOLS ARE DESIGNED, MANUFACTURED AND TESTED USING SIGNODE MANUFACTURED STRAPPING, SEALS AND PARTS. USE OF NON-SIGNODE MANUFACTURED STRAPPING AND SEALS MAY RESULT IN STRAP BREAKAGE OR JOINT SEPARATION OR DAMAGE TO THE PRODUCT. IN NO EVENT SHALL SIGNODE BE LIABLE FOR INJURIES OR DAMAGES OF ANY KIND RESULTING, IN WHOLE OR IN PART, FROM THE USE OF NON-SIGNODE MANUFACTURED STRAPPING AND SEALS. USE OF NON-SIGNODE MANUFACTURED REPLACEMENT PARTS AND SIGNODE PRODUCTS THAT ARE MODIFIED OR ALTERED BY A PARTY OTHER THAN SIGNODE, MISUSED OR ABUSED, SHALL VOID ALL WARRANTIES OTHERWISE APPLICABLE TO THE PRODUCTS OR SERVICES.

## DISCLAIMER of FURTHER WARRANTIES

SIGNODE'S WARRANTIES AND REPRESENTATIONS ARE SPECIFICALLY LIMITED TO THOSE SET FORTH ABOVE. SIGNODE MAKES NO WARRANTIES OR REPRESENTATIONS OF MERCHANTABILITY OR FITNESS FOR A PARTICULAR PURPOSE. SIGNODE MAKES NO OTHER WARRANTIES EXPRESS OR IMPLIED. IN NO EVENT SHALL SIGNODE BE LIABLE FOR CONSEQUENTIAL, INCIDENTAL, DIRECT, INDIRECT, PUNITIVE OR SPECIAL DAMAGES (INCLUDING BUT NOT LIMITED TO LOSS OF PROFITS, BUSINESS OR GOODWILL, INCREASED COSTS OF OPERATIONS, OR COST OF SUBSTITUTE GOODS) EVEN IF ADVISED OF THE LIKELIHOOD OF SUCH DAMAGES, WHETHER OR NOT BASED UPON SIGNODE'S NEGLIGENCE OR BREACH OF WARRANTY OR STRICT LIABILITY IN TORT OR ANY OTHER CAUSE OF ACTION.

Considerable effort has been made to ensure that this product conforms to our high quality standards. However, should you experience any difficulties, please contact your Sales Representative providing samples and the manufacturing code specified on the tool.

Thank you for your help.

SIGNODE ENGINEERED PACKAGING SOLUTIONS  
Hand Tool Division  
3700 W. Lake Avenue, Glenview, Illinois 60026